

JDN ULTRA-LOW MONORAIL HOISTS

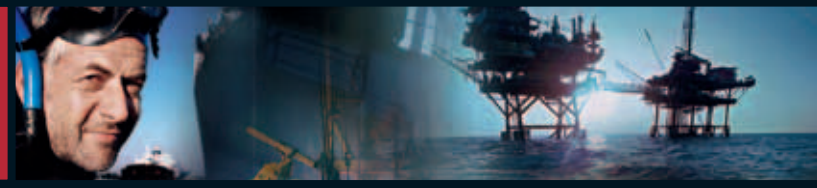

J. D. NEUHAUS
powered by air!

JDN ULTRA-LOW MONORAIL HOISTS



**Carrying capacities:
2 t up to 100 t
Air pressure: 85 psi**

Where loads have to be lifted and transported in extremely reduced spaces the **JDN Ultra-Low Monorail Hoists** provide the ideal solution. For example the Ultra-Low Monorail Hoist with a load capacity of 6 t has a headroom of only 230 mm.

Standard Features

- Ideally suited for working in hazardous areas (explosion risk)
- Insensitive to humidity, dust and temperatures from -20°C up to +70°C
- Extremely low headroom
- Low air consumption
- Available with increased spark protection

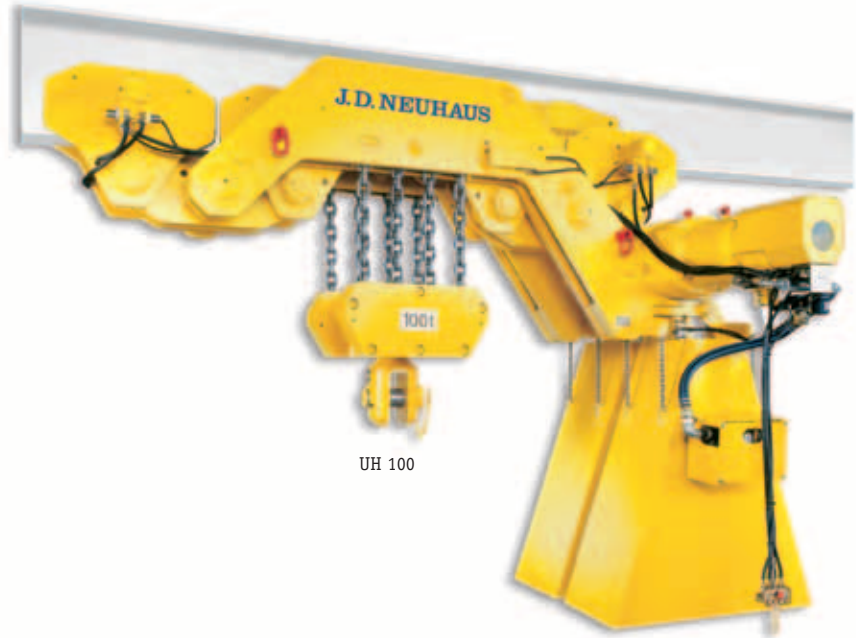

UH 100

Technical Data

Type		UH 4	UH 6	UH 8	UH 12	UH 16
Carrying capacity	mt	4	6	8	12	16
Number of chain strands		2	2	4	4	4
Motor output	kW	2.5	2.5	2.5	2.5	2.5
Air pressure	PSI bar	85 6	85 6	85 6	85 6	85 6
Lifting speed at full load	ft/min m/min	9.84 3.0	6.56 2.0	4.59 1.4	2.95 0.9	2.13 0.65
Lifting speed without load	ft/min m/min	19.69 6.0	14.76 4.5	9.51 2.9	7.22 2.2	3.94 1.2
Lowering speed at full load	ft/min m/min	24.61 7.5	17.06 5.2	11.81 3.6	8.20 2.5	4.92 1.5
Air consumption lifting – full load	cfm m ³ /min	141.26 4.0	141.26 4.0	141.26 4.0	141.26 4.0	141.26 4.0
Air consumption lowering – full load	cfm m ³ /min	194.23 5.5	194.23 5.5	194.23 5.5	194.23 5.5	194.23 5.5
Air connection		G 3/4	G 3/4	G 3/4	G 3/4	G 3/4
Hose dimension (Ø inside)	inch mm	3/4 19	3/4 19	3/4 19	3/4 19	3/4 19
Weight with standard lift	lbs kg	1014.13 460	1036.17 470	1190.50 540	1212.54 550	1234.60 560
Chain dimension	mm	13 x 36	13 x 36	13 x 36	13 x 36	13 x 36
Weight of chain	lbs/ft kg/m	2.6 3.8	2.6 3.8	2.6 3.8	2.6 3.8	2.6 3.8
Standard lift	ft m	10 3	10 3	10 3	10 3	10 3
Length of control at standard lift	ft m	6.5 2	6.5 2	6.5 2	6.5 2	6.5 2
Noise level at full load ¹ – lifting	dB(A)	78	78	78	78	78
Noise level at full load ¹ – lowering	dB(A)	80	80	80	80	80

¹Measured at 1m distance acc. to DIN 45635 part 20
Group mechanism: M3 (1 Bm)
Technical data for higher capacities on request.



J.D. NEUHAUS
powered by air!

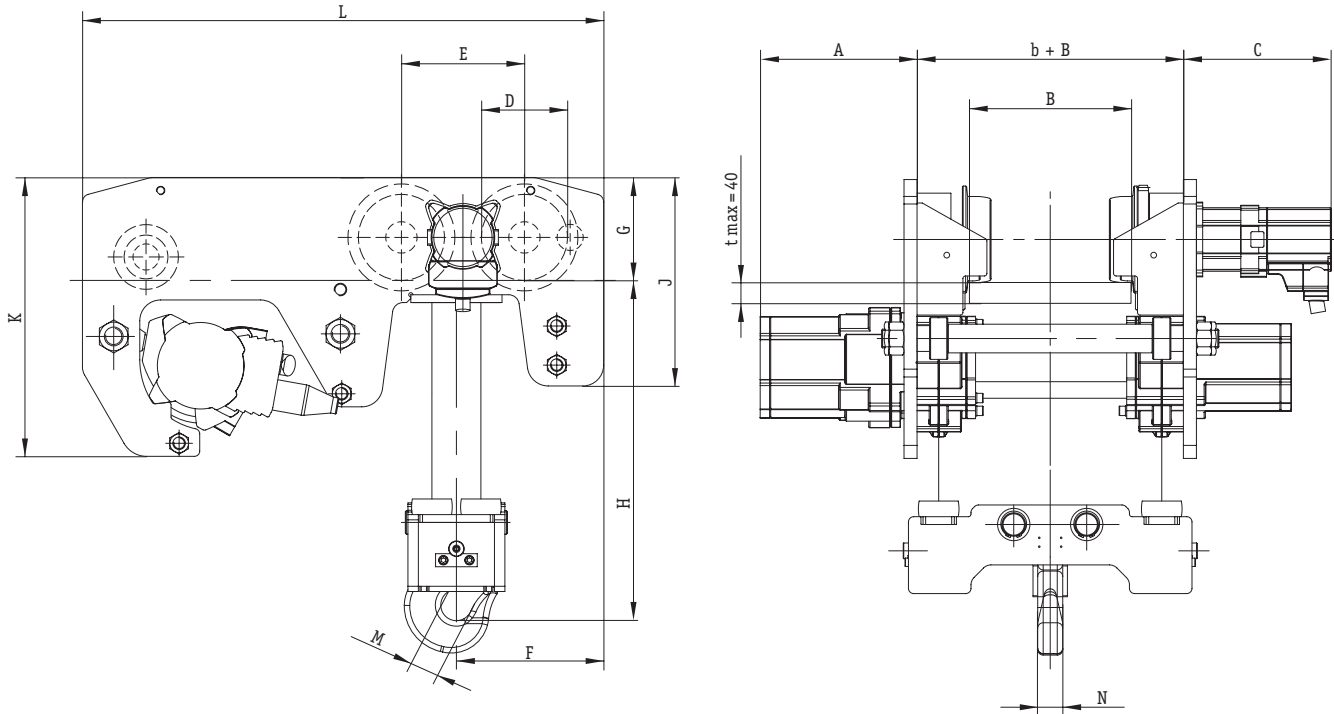

Dimensions

Type		UH 4	UH 6	UH 8	UH 12	UH 16
A	inch	7.68	12.01	7.68	12.01	12.01
	mm	195	305	195	305	305
B	inch	7.87	7.87	7.87	7.87	7.87
	mm	200	200	200	200	200
C	inch	11.16	11.16	11.16	11.16	11.16
	mm	284	284	284	284	284
D	inch	6.50	6.50	6.50	6.50	6.50
	mm	165	165	165	165	165
E	inch	9.29	9.29	9.29	9.29	9.29
	mm	236	236	236	236	236
F	inch	12.99	12.99	11.14	11.14	11.14
	mm	330	330	283	283	283
G	inch	7.78	7.78	7.78	7.78	7.78
	mm	197.5	197.5	197.5	197.5	197.5
H min. 150 <= b <= 310	inch	9.06	9.06	-	-	-
	mm	230	230	-	-	-
H min. 150 <= b <= 230	inch	-	-	11.61	11.61	13.15
	mm	-	-	295	295	334
H min. 230 <= b <= 310	inch	-	-	10.87	10.87	12.40
	mm	-	-	276	276	315
J	inch	15.75	15.75	15.75	15.75	15.75
	mm	400	400	400	400	400
K	inch	21.06	21.06	21.06	21.06	21.06
	mm	535	535	535	535	535
L	inch	39.37	39.37	39.37	39.37	39.37
	mm	1000	1000	1000	1000	1000
M	inch	1.57	1.57	1.73	1.73	2.09
	mm	40	40	44	44	53
N	inch	2.01	2.01	2.60	2.60	3.23
	mm	51	51	66	66	82

Dimensions for higher capacities on request.